

Assembly

1. Check measures
2. Mount the base bottom profile (Detail B)
3. Level with jack-up bricks and mount upper section of base (Detail B)
4. Mount the glass partition (Detail A-B-C)

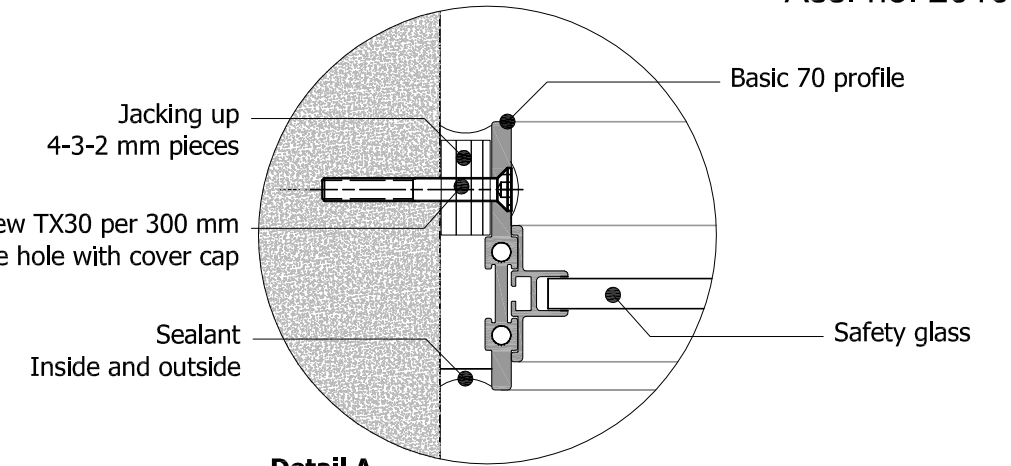

Detail A
1:2

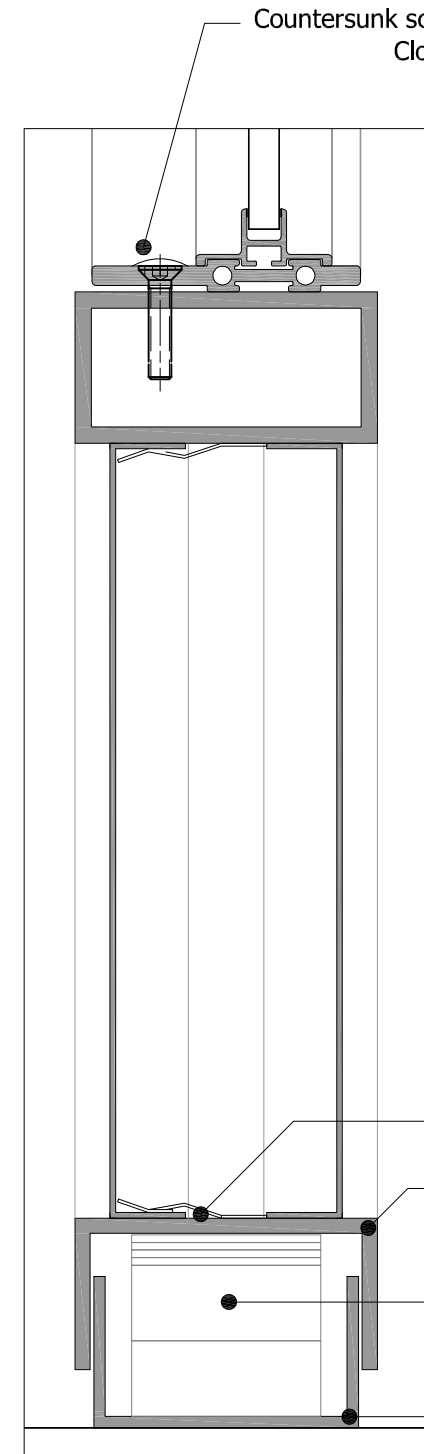
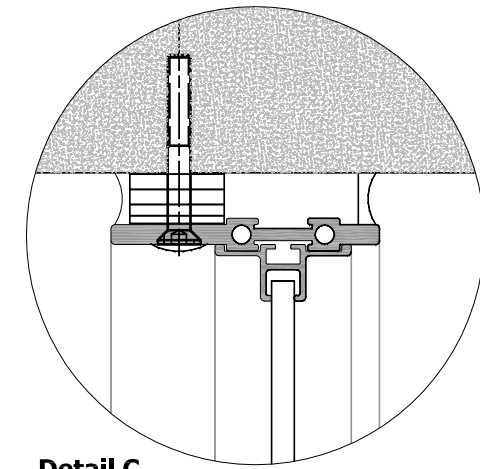

Detail C
1:2
Specifications as in detail A

Detail B
1:2

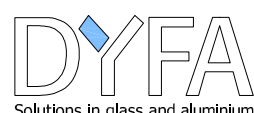
Sign.	Appr.	Date	Project	Description	Format	Scale
CS	-	02-10-2015	NY	Interior	A3	1:20 - 1:2
 Finlandsvej 12 DK-5700 Svendborg +45 91 55 33 55 kontakt@dyfa.dk www.dyfa.dk					Drawing no.	
					201007	
High base panel and Basic 70 partition					Revision	Revision date
Assembly principles					-	-